

6500DC A-1044 Dual Motor Wireless Controller Kits

READ ALL DIRECTIONS FIRST BEFORE PROCEEDING

NOTE: SEE THE PROGRAM INSTRUCTIONS BEFORE OPERATING THE FIRST TIME.
DO NOT REMOVE THE TRANSMITTER BATTERY

Please follow programming directions. Always disconnect power and ground cable and turn off breaker when not in use. Do not mount the receiver near a vibrator or in an area where damage may occur. Use rubber grommets when mounting receiver box. Receiver may be mounted in another plastic box with antenna exposed. The provided breaker must be used. Use anti-seize or grease on the receiver cover screws. Dielectric grease must be used on connections. Before connecting this device to equipment make absolutely sure the equipments components are operating properly and freely. **Never jump start or put a battery booster on the vehicle without first disconnecting power to the receiver unit.** Failure to do so will permanently damage the unit (no warranty for burnt boards whatsoever).

For use with 12 volt dc voltage only

How it Works:

The 6500DC Dual DC Motor Controller that provides RPM control for up to 2 single DC motors. A up to 60AMP (Larger motor or conveyor or auger motor) and up to 40 amps to Motor B (smaller motor or spinner motor) 2 separate outputs, (3 speeds per motor low medium and full power)

- Automatic shut down if motor is locked up. Unit will shut down for approx. 30-60 seconds before you can attempt a restart.
- Automatic shut off if the current draws do not drop below the rated amps after 5 to 7 seconds. Once again, the receiver will shut down for 30 to 60 seconds. You will need to investigate the problem as if you continue to override the control you will cause permanent damage to the receiver, motor or wiring.

Kit contains: note contents varies by kit ordered and will not be contained in transmitter or receiver only kits

- Receiver box with external antenna
- Junction wiring box for connections and optional switch box for added switched accessory (requires fabrication , slots can be cut for wiring and switches added)
- Transmitter
- Breaker (must be installed)
- Short battery cable from positive battery cable to in lug breaker
- 24' vehicle Power Ground cable Black to Positive battery Red to out lug on breaker
- Relay and socket for optional vibrator or on off accessory see diagram
- 4 seal-tite wiring connectors FOR SMALLER WIRES
- 4 anti-vibration washers for mounting receiver and junction box
- 4 sheet metal screws #10x1
- 4 Scotch locks
- 2 crimp on lugs
- Heat shrink
- 2 yellow heat shrink butt connectors FOR MOTOR CONNECTIONS
- 4 blue heat shrink butt connectors
- 4 velcro strips for mounting receiver in junction box

Due to the numerous installation applications of this unit please follow all directions carefully or seek the help of someone that can.

NOT INCLUDED- IF YOUR UNIT HAS A REMOVEABLE SPINNER YOU WILL WANT TO MAKE A QUICK DISCONNECT PLUG TO THE SPINNER

WARNING – spreader vibrators are made for momentary use only. Extended use will cause the vibrator to heat up and require more amperage which will damage the wiring , relay and eventually the receiver unit. As a precaution you may install a 10 amp inline fuse on the hot wire of the vibrator relay (wire that would connect to relay Pin 87)

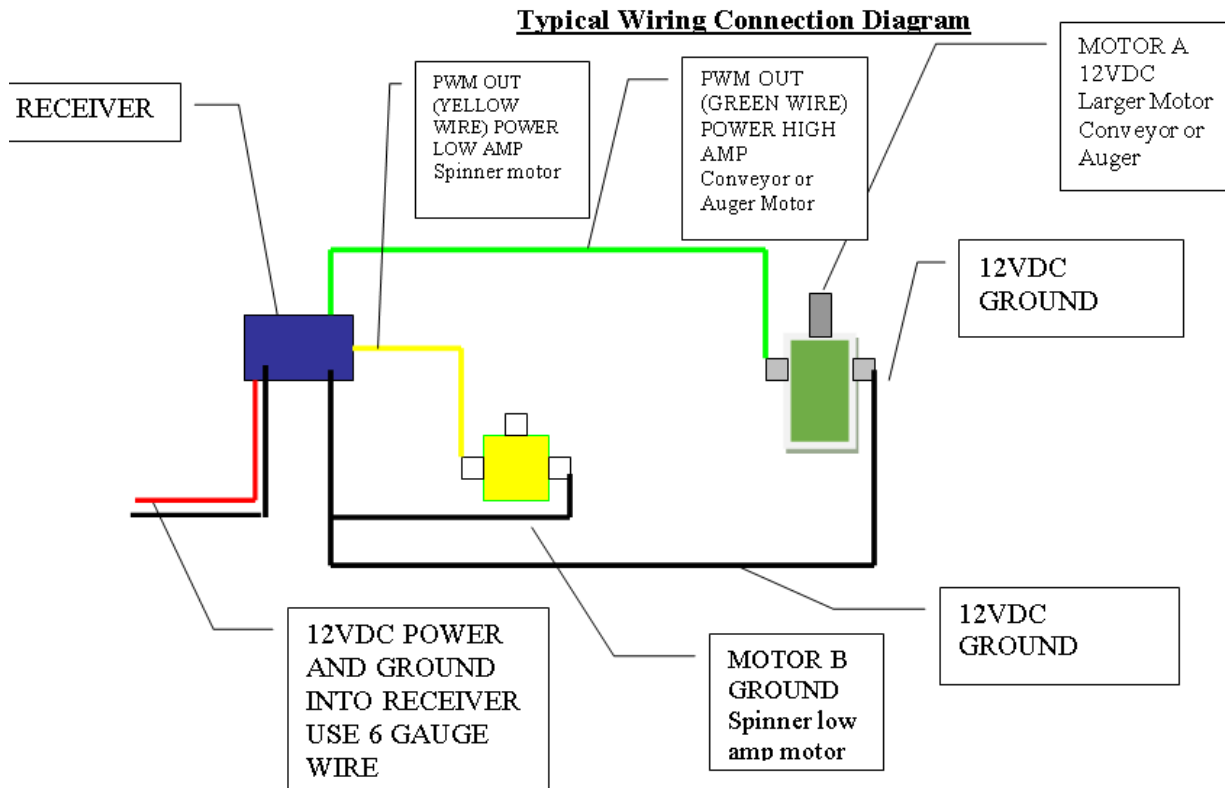

WIRING DIRECTIONS read carefully **DUAL motor instructions**

IMPORTANT you must cap off any wires not used failure to do this will cause damage to the unit.

1. Remove all current OEM Wiring, module boxes and switches from your salt spreader. You will not need any of it ever again.
2. Mount the wireless controller receiver and junction box on the driver's side of the salt spreader. Drill two holes on the junction box as needed in order to allow all connections to be made here. You may also install a manual switch to use with the auxiliary hot wire supplied if needed for a LED light or low amp device.
3. Use the provided purple seal-tite connectors for all connections at the wireless receiver.
4. Determine which motor controls your auger or conveyor, and which motor controls your spreader spinner.
5. Connect the "green" receiver wire to the hot side of the auger / conveyor motor.
6. Connect the "black" ground wire to the ground side of the auger motor.
7. Connect the "yellow" wire from receiver to the hot side of the spinner motor.
8. Connect the "black" ground wire from the receiver using the included connector with both spreader motor grounds. You will have (3) three ground wires total in this connector. If you are connecting the optional vibrator or auxiliary light, this ground will also be connected. Simply make a short black jumper wire and use another connector so all ground wires are "tied" together.

9. **NOTE: If your auger/conveyor or spinner motors are operating in reverse or start up automatically upon connection, you need to switch the power and ground wires so the spinner or auger motors run in the correct direction.**
10. Always test the functioning of your motors before closing the lids on the seal-tite connectors. We also suggest tightening all connections twice and adding dielectric grease before closing the covers on the seal-tite connections.
11. At the truck's battery, use the short power cord to go from the positive battery to the "in" lug of the provided circuit breaker
12. Connect the red positive of the 24' truck cable to the "out" lug of the breaker provided.
13. Connect the black ground of the 24' truck cable to the negative post of the truck's battery.
 - a. **NOTE: If you are separating the positive and negative wiring harness, be careful not to tear into the casing. Inspect and tape if needed.**
14. Secure the breaker under the hood of the truck and away from direct heat put off by the engine. Tape and protect all bare connections.
15. Run and secure the 24' quick disconnect power/ground cable to the desired location and away from direct heat/sharp objects.
16. Use the included dust covers on each end of the power cords to protect from corrosion.

IMPORTANT MAINTENANCE INFORMATION

- Use dielectric grease and clean connections on a regular basis
- Always unplug the power cords (positive/negative plug) when not in use. If you do not, this will enhance corrosion and cause your connections to fail.
- Do not use the wireless transmitter/key fob if frozen. Warm it up first before use or it may not operate properly.
- **Do not jump-start the vehicle with power connected to the spreader. This may burn out the unit and void warranty.**

MT-8 Wireless Transmitter

The MT-8 wireless transmitter is 2.87" x 4.65" in size. This industrial unit can be mated with Control All Wireless's current lineup of wireless receivers. All MT-8 transmitters come from the factory with a pre-install address (1 in 16 million). The MT-8 will transmit up to 8 individual signals to the wireless receiver using buttons 1 thru 8.

Button Indicator LED.
This LED will light up when you press any of the 8 buttons, and go off when you release the button. If the LED doesn't light up the MT-8 will still work but it's time to change batteries

Programming indicator LED.
This LED will light up for 15 seconds after you press the programming button on the back and will go out on its own.



Programming

- Turn on the top to the right
- Make sure receiver is off. You can test if the black button

transmitter by toggling the switch on

has power and the cover of the receiver the receiver has power by depressing inside. The right red led will begin to

flash if power is present. Wait until the light goes out before continuing with programming.

- You will want to program the MT-8 remote within a couple feet of the receiver
- MT-8 programming hole is found on backside of MT-8
- Using a paperclip carefully depress the button through the hole on the backside of the MT-8
- Flip the MT-8 over and you will see a red LED flashing on the upper right side of the transmitter. While the LED is flashing, push and release each of the 8 buttons one at a time.
- LED will stop flashing after 15 seconds of pushing programming button. Wait until the light quits flashing before continuing.
- Next depress the black button inside the receiver. The receiver led will begin to flash. Again depress each button one at a time on the transmitter. When finished wait until the receiver light stops blinking. You are now programmed test all functions. Note if a function seems to be missing. Reprogram.

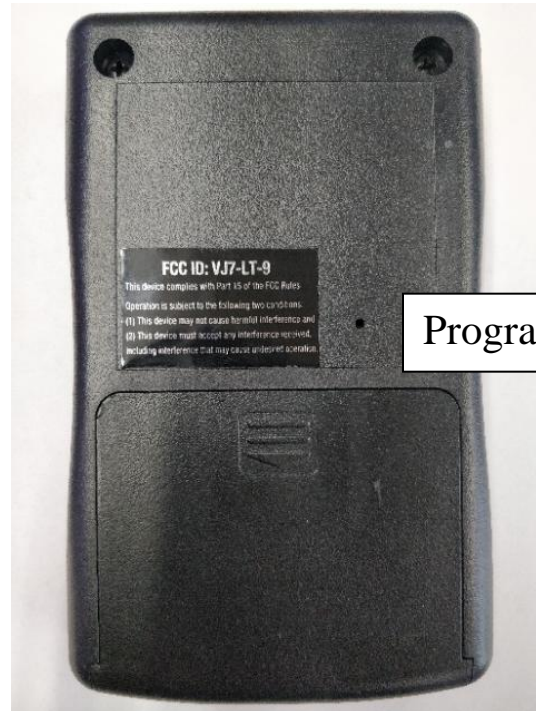

Programming Hole

Battery

Battery Cover

Replacement

The MT-8 uses 2 standard Alkaline AA batteries. If the MT-8 is going to be used in below 0 Fahrenheit conditions, we recommend changing the batteries to Lithium. In normal use it will provide 1 to 2 years of operation. To replace the battery, remove the cover on backside of MT-8. Observe the battery polarity when replacing.

In rare instances the batteries may lose connection with the terminals and need to be rolled.

Shown above is a typical transmitter for wireless operation of a Dual 12VDC motor spreader. The button functions are as follows:

- Conveyor or motor 1: Slow, medium, fast. 1/3 increments between speeds.
- Spinner or motor 2: Slow, medium, fast. 1/3 increments between speeds.
- On/Off/Shuts down the receiver unit. Must be powered on again using the on/off button.
- Vibrator On/Off single switch can also be used for a LED light. Each single press of the button toggles on/off.

NOTE: It is recommended that when the DC motors are under high loads, that the control first be started at medium to high speed for the first 1 to 5 seconds of operation to avoid damage to the motor or controller as well as voiding the warranty. Always start your spinner motor first.

TROUBLESHOOTING – READ THIS

- Do not change your transmitter battery unless you have followed proper troubleshooting for programming and reprogramming your transmitter to the receiver (see above).
- Always test your functions before loading your spreader so you can visually see and hear the different RPM functions.
- Make sure your discharge chutes are open and baffles adjusted to the material you are using.
- Keep the transmitter out of extreme cold or warm up before using.
- To verify power to the receiver, remove the cover and press the black button. If it blinks red, there is power to the unit.
- Keep power/ground connections clean and tight.
- Use dielectric grease and seal backside of all connections.
- Always disconnect power and ground cable when not in use.
- Always start spinner motor first before starting auger.
- Do not jumpstart your vehicle while the spreader is connected.
- If a timeout situation occurs on your spreader and continues to re-occur beyond two times, the operator needs to check for reasons why the spreader motors will not turn. Continually trying to start a jammed motor will cause damage to the receiver and the motor.
- Transmitters are a wearable part. We suggest having a spare in case you would lose it.

OPTIONAL VIBRATOR WIRING INSTRUCTIONS

Relay Instructions for vibrator or light connection. Follow these directions carefully. These directions should ONLY be followed with our relay socket.

A relay is basically a switching device. The difference is that it can handle more amperage than a typical switch allowing a typical switching device to power high amperage devices.

1. Connect 14 gauge red with black tracer to the blue wire on the relay socket or pin 30 of the relay
2. Connect one of the other 14 gauge red wires to the white wire of the relay socket or pin 85
3. You will be left with one extra red wire. This wire is hot and is used for switched additional accessories. This wire is not operated via wireless. You may install a switch in the junction box and operate low amp accessories, always use a relay if attempting to operate a higher amp device. If not using this wire it must be capped off.
4. Connect the yellow wire from the relay socket or pin 87 on the relay to the hot wire of the accessory. If connecting a vibrator it will not matter which of the two wires you choose on most vibrators, if there is a red and black wire red is power black is ground. If a black and white wire is coming out of the vibrator use black as power white as ground.
5. Connect the purple 18 gauge wire from the receiver harness to the black wire on the relay socket or pin 86 of the relay.

The middle pin 87A is not used, Pic below is looking at the relay with the pins facing you.

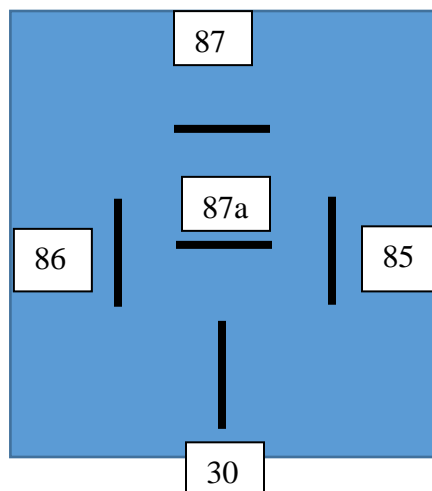

WARRANTY INFORMATION

- Limited 1-year warranty on wireless receiver and wireless transmitter. See specific wireless warranty on the website for in depth details.
- Check online for any updated directions at <https://www.controlallwireless.com> or User must maintain good, clean and properly connected connections in order for proper operation and to avoid damage to the receiver as well as possibly voiding the warranty. It is recommended that you use a battery disconnect when the unit is not in use, as continuous powered wiring will enhance corrosion of wiring. Always disconnect power when not in use!
- Due to the corrosive environment in which these units are used, you must keep connections and the inside of the receiver clean from salt. Salt dust will corrode the exposed components of the board.
- We have no control over the end user's method used to install our wireless controllers. For any warranty consideration, all units must be sent back for inspection and testing. Burnt boards or any modification of factory wires of any type means that failure to follow proper installation has occurred. With electronics, care needs to be taken and directions need to be followed in order to keep your warranty in tact. **All warranty claims will require pictures of the installation along with battery, fuse or breaker installation** before returning an item.no exceptions.

WARNING – spreader vibrators are made for momentary use only. Extended use will cause the vibrator to heat up and require more amperage which will damage the wiring , relay and eventually the receiver unit. As a precaution you may install a 10 amp inline fuse on the hot wire of the vibrator relay (wire that would connect to relay Pin 87)