

# Control All Wireless

NOTE THE TRANSMITTER HAS BEEN PRE-PROGRAMMED TO THE UNIT

## 650DC1 Wireless Variable Speed DC Motor Controller

### How it Works:

The 650DC1 Wireless Dual DC Motor Controller that provides RPM control for 2 single, 2 pole, DC motors that can output up to 200 amps to Motor A and up to 100 amps to Motor B for up to 1 second and a maximum continuous amperage of 75 to Motor A and up to 40amps to Motor B. The RPM control is done by providing the user 2 separate outputs, approximately 1/3 of the maximum motor RPM for each motor. The 650DC1 also incorporates a full RPM “Blast” feature that runs both motors full speed for 6 to 8 seconds and then automatically returns to the previous speed and an E-Stop.

To protect the motor and electronics, the 650DC1 has built-in safety circuits.

- Automatic shut down if motor is locked up. How this is done is if the receiver senses a current draw of more than the rated amps for more than approximately 1000mS the unit will shut down from 1 to 30 seconds and must be restarted using button #8.
- Automatic shut off if the current draws do not drop below the rated amps after 5 to 7 seconds. Once again, the receiver will shut down for 1 to 30 seconds.

### Typical Wiring Connection Diagram

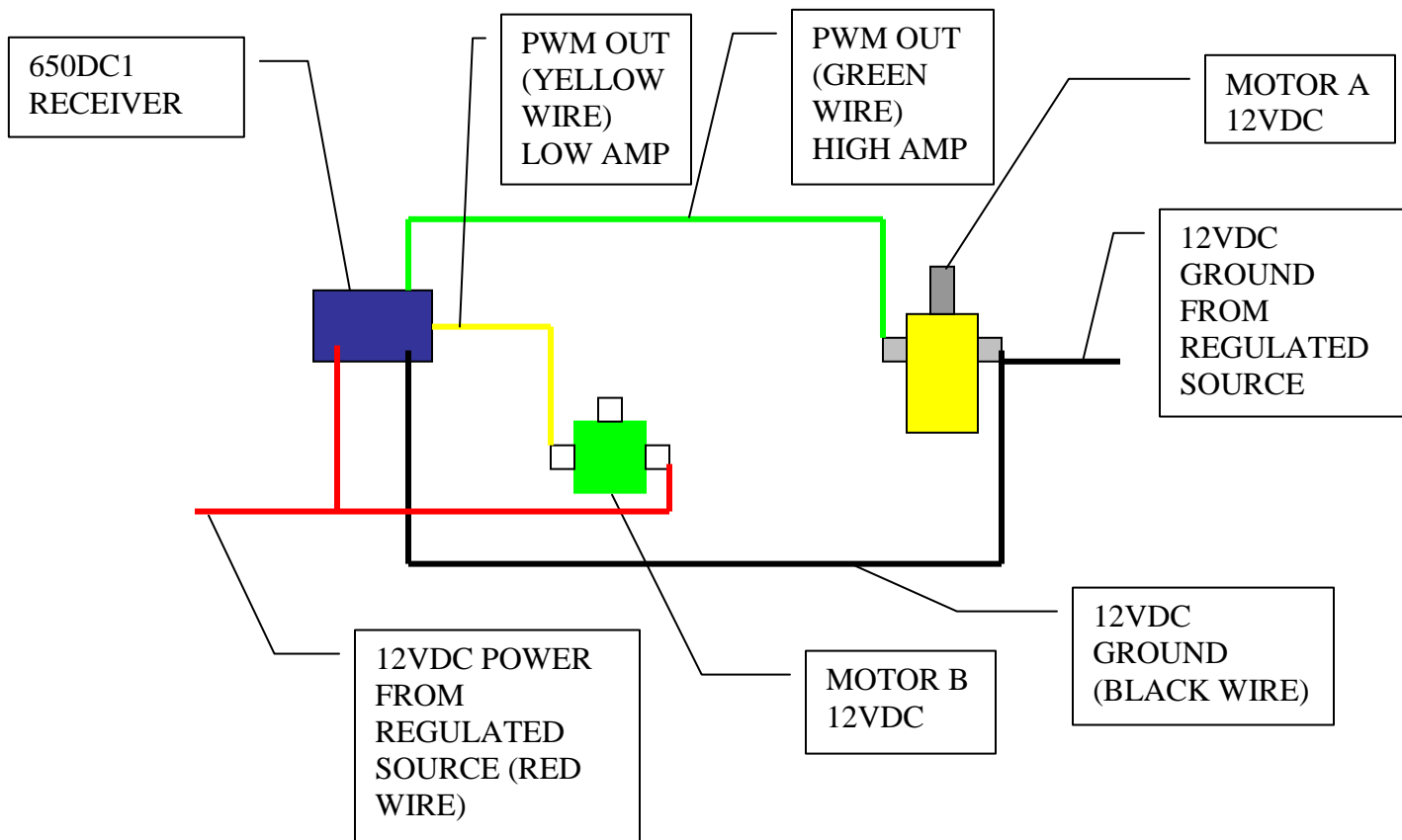

**\*\*\*User must maintain good, clean properly connected connections for proper operation and to avoid damage to the receiver and void the warranty\*\*\***

**OPERATION:**



**650 STANDARD TRANSMITTER**

Shown above is a typical transmitter for wireless operation of a 12VDC motor. The button functions are as follows:

1. Slow speed setting of approximately 1/3rd of full speed of Motor "A".
2. Slow speed setting of approximately 1/3rd of full speed of Motor "B".
3. Medium speed setting of approximately 2/3<sup>rd</sup>'s of full speed of Motor "A".
4. Medium speed setting of approximately 2/3<sup>rd</sup>'s of full speed of Motor "B".
5. Full speed setting of approximately 3/3<sup>rd</sup>'s of full speed of Motor "A".
6. Full speed setting of approximately 3/3<sup>rd</sup>'s of full speed of Motor "B".
7. **Blast/** A timed 6 to 8 second full speed to both Motors with return to previous speed
8. **OFF/** Shuts down the receiver unit. Must be turned on again using Button #8

**\*\*\*\* It is recommended that when the DC motor/s is under high loads that the control first be started at medium to high speed for the first 1 to 5 seconds of operation to avoid damage to the motor or control and may void the warranty\*\*\*\***

## **Programming Transmitter to Receiver:**

The following are the step by step procedures for setting the unique address between the transmitter and receiver or adding extra transmitters to the receiver (up to 40 transmitters).

1. Disconnect both the green and yellow PWM wires from motors and cover terminal ends.
2. On the backside of the Transmitter, use a paperclip and insert it in the hole next to the clear blue window. Once the programming button is depressed, a blue LED will begin to blink for 15 seconds. Flip the Transmitter over and firmly depress all 8 buttons starting with the #1 button within 15 seconds. Now the Transmitter has acquired a 1 in 16 million address. **MAKE SURE THE BLUE LIGHT STOPS BLINKING BEFORE CONTINUING.**
3. Next step is to remove the receiver box cover noting the drain hole positions in the cover. Hook up the Power (red wire) and Ground (black wire) to a 12VDC power source. Inside the box next to the red LED depress the black programming button. The red LED will begin to flash for 15 seconds. Take the Transmitter while the red LED is flashing and firmly depress the #1 button within the 15 seconds. Now the unique address of the Transmitter will only be recognized by that matched receiver. The red LED will automatically shut off after 15 seconds. To make sure the programming procedure was successful, depress any of the Transmitter buttons and the red LED in the receiver should light. Re-install the cover noting drain hole position, depress the #8 button on the transmitter to make sure the unit is off and re-connect the PWM (green/yellow wires) to the motor. The 650 is now ready to operate the DC motor. **Warning\*\*Damage to the receiver can be caused by bad or open connections through “Inductive Feedback” from the motor. Make sure all wiring connections are connected properly and tight to prevent damage and void warranty. Never disconnect wiring while motor is running.**

## **Specifications:**

- Up to 200 amps of output to Motor “A” and up to 100 amps to Motor “B” for up to 1 second.
- Continuous output of up to 75 amps on Motor “A” and 40 amps on Motor “B”.
- 3 separate motor speed outputs of approximately 1/3,2/3,3/3, of both motors current draw.
- Built in E-Stop using #8 button.
- 12VDC with spike protection up to 40VDC
- Built-in over current safety protection. If a lock-up condition occurs at the motors or motor causing them to draw more than 200 amps, the unit will automatically shut down and must be turned back on using the #8 button after the circuit temperature drops to an acceptable range taking 1 to 30 seconds. **Warning:** If this situation continues to re-occur the operator needs to check for reasons why the motors will not turn. Continually trying to start a jammed motor will can cause damage to the receiver and motor.